

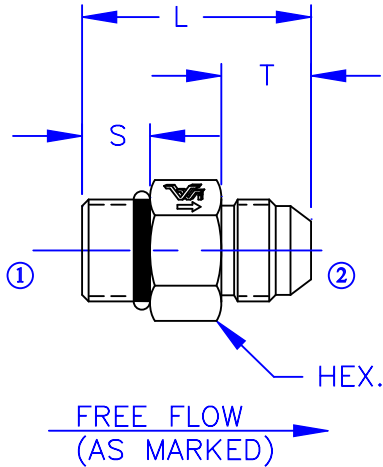

CHECK VALVE

IN-LINE HIGH CAPACITY

1100R SERIES
POPPET TYPE
MALE SAE TO MALE JIC



DESCRIPTION

- AN IN-LINE STYLE CHECK VALVE INTENDED FOR BLOCKING FLUID FLOW.

OPERATION

- FLOW FROM "1" TO "2" IS ALLOWED WITH A STANDARD CRACK PRESSURE OF 5 PSI.
- FLOW FROM "2" TO "1" IS BLOCKED WITH A SPRING BIAS TO ASSIST IN STATIC AND LOW LOAD CONDITIONS.

FEATURES

- STEEL BODY AND POPPET.
- FULLY ENCAPSULATED SPRING.
- NO SNAP RING.
- LOW INTERNAL LEAKAGE, 5 DPM.
- HIGH FLOW CAPACITY.
- * SPECIAL CRACK PRESSURES AVAILABLE UPON REQUEST.

- SPECIFICATIONS -	
HYDRAULIC SYMBOL	
OPERATING PRESSURE	3500 PSI
TEMPERATURE RANGE	250°F TO -40°F
STANDARD CRACK PRESSURE	5 PSI *
ALL DIMENSIONS IN INCHES	

- ORDERING INFORMATION -	
ASSEMBLY NUMBER	11XXR-XX
SERIES NUMBER	11
THREAD SIZE	XX
CRACK PRESSURE (PSI) (IF NON-STANDARD)	

MODEL	INLET 1	OUTLET 2	THREAD	L	T	S	HEX.
1104R	#4 SAE	#4 JIC	7/16-20	1.26	0.550	0.360	0.562
1106R	#6 SAE	#6 JIC	9/16-18	1.28	0.555	0.390	0.750
1108R	#8 SAE	#8 JIC	3/4-16	1.60	0.655	0.440	0.875
1110R	#10 SAE	#10 JIC	7/8-14	1.86	0.760	0.500	1.000
1112R	#12 SAE	#12 JIC	1 1/16-12	2.18	0.860	0.594	1.250



Vonberg Valve, inc.
 HYDRAULIC VALVE SPECIALISTS

3800 INDUSTRIAL AVE.
 ROLLING MEADOWS, IL 60008-1085
 PH: (847) 259-3800 FAX: (847) 259-3997