



PILOT CHECK VALVE

1700 SERIES

CARTRIDGE

POPPET TYPE
PILOT TO OPEN

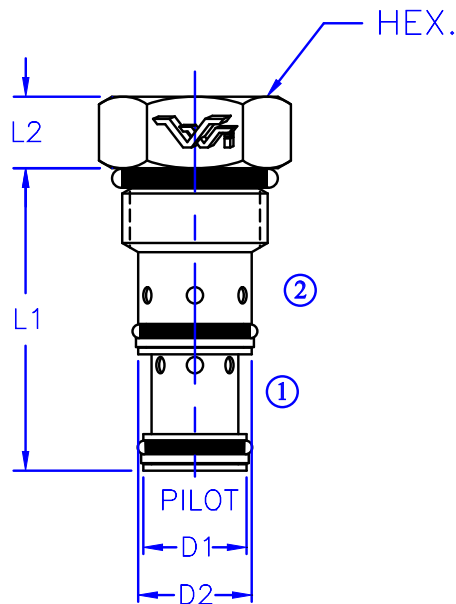

DESCRIPTION

- A CARTRIDGE STYLE, PILOT TO OPEN CHECK VALVE INTENDED FOR BLOCKING FLUID FLOW.

OPERATION

- FLOW FROM "1" TO "2" IS ALLOWED WITH A STANDARD CRACK PRESSURE OF 5 PSI.
- FLOW FROM "2" TO "1" IS NORMALLY BLOCKED WITH A SPRING BIAS TO ASSIST IN STATIC AND LOW LOAD CONDITIONS.
- THE CARTRIDGE HAS A 4:1 PILOT RATIO TO ALLOW FLOW FROM "1" TO "2".

FEATURES

- INDUSTRY COMMON CAVITY.
- LOW INTERNAL LEAKAGE, 5 DPM.
- STANDARD PILOT RATIO: 4:1
- SPECIAL PILOT RATIOS AVAILABLE UPON REQUEST.
- STEEL COMPONENTS.

- SPECIFICATIONS -

HYDRAULIC SYMBOL	 PILOT
PRESSURE RANGE	50 PSI TO 3500 PSI
TEMPERATURE RANGE	250°F TO -40°F
INTERNAL LEAKAGE	5 DROPS / MIN. @ 3500PSI MAX.
ALL DIMENSIONS IN INCHES	

- ORDERING INFORMATION -

ASSEMBLY NUMBER _____ 17XXX
 SERIES NUMBER _____
 PORT SIZE _____
 PILOT PISTON TYPE _____
 BLANK - UNSEALED
 "P" - O-RING SEALED

MODEL	THREAD	CAVITY	RATED FLOW	L1	L2	D1	D2	HEX
NEW 1706	9/16-18	6-3	3.0 GPM	1.23	0.27	0.437/0.438	0.467/0.468	0.687
1708	3/4-16	8-3	6.0 GPM	1.63	0.37	0.558/0.560	0.621/0.623	0.875
1710	7/8-14	10-3	10.0 GPM	1.82	0.43	0.621/0.623	0.683/0.685	1.000
1712	1 1/16-12	12-3	20.0 GPM	2.63	0.52	0.870/0.873	0.933/0.935	1.250
1716	1 5/16-12	16-3	30.0 GPM	2.88	0.63	1.058/1.060	1.120/1.122	1.500



Vonberg Valve, inc.

HYDRAULIC VALVE SPECIALISTS

3800 INDUSTRIAL AVE.
 ROLLING MEADOWS, IL 60008-1085
 PH: (847) 259-3800 FAX: (847) 259-3997