



CHECK VALVE

1800 SERIES

CARTRIDGE

POPPET TYPE

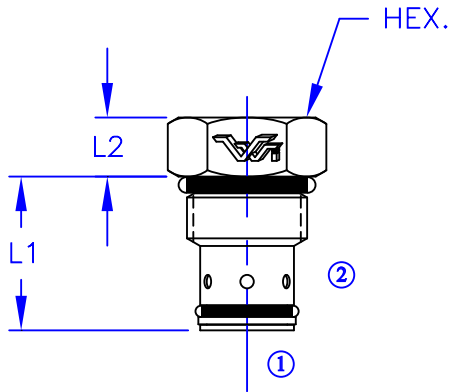

DESCRIPTION

- A CARTRIDGE STYLE, CHECK VALVE INTENDED FOR BLOCKING FLUID FLOW.

OPERATION

- FLOW FROM "1" TO "2" IS ALLOWED WITH A STANDARD CRACK PRESSURE OF 5 PSI.
- FLOW FROM "2" TO "1" IS BLOCKED WITH A SPRING BIAS TO ASSIST IN STATIC AND LOW LOAD CONDITIONS.

FEATURES

- INDUSTRY COMMON CAVITY.
- LOW INTERNAL LEAKAGE, 5 DPM.
- STEEL COMPONENTS.
- * SPECIAL CRACK PRESSURES AVAILABLE UPON REQUEST.

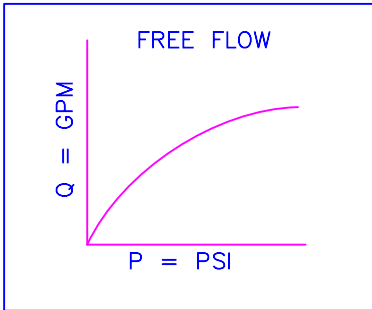

- SPECIFICATIONS -

HYDRAULIC SYMBOL	
OPERATING PRESSURE	3500 PSI
TEMPERATURE RANGE	250°F TO -40°F
STANDARD CRACK PRESSURE	5 PSI *
INTERNAL LEAKAGE	5 DROPS / MIN. @ 3500PSI MAX.
ALL DIMENSIONS IN INCHES	

- ORDERING INFORMATION -

ASSEMBLY NUMBER 18XX-XX
 SERIES NUMBER _____
 PORT SIZE _____
 CRACK PRESSURE (PSI) _____
 (IF NON-STANDARD)

MODEL	THREAD	CAVITY	RATED FLOW	L1	L2	HEX
NEW 1804	7/16-20	4-2	2.0 GPM	0.94	0.52	0.56
NEW 1806	9/16-18	6-2	4.0 GPM	0.94	0.52	0.69
1808	3/4-16	8-2	6.0 GPM	1.10	0.36	0.88
1810	7/8-14	10-2	10.0 GPM	1.25	0.40	1.00
1812	1 1/16-12	12-2	20.0 GPM	1.81	0.49	1.25
1816	1 5/16-12	16-2	30.0 GPM	1.75	0.55	1.50



Vonberg Valve, inc.

HYDRAULIC VALVE SPECIALISTS

3800 INDUSTRIAL AVE.
 ROLLING MEADOWS, IL 60008-1085
 PH: (847) 259-3800 FAX: (847) 259-3997