

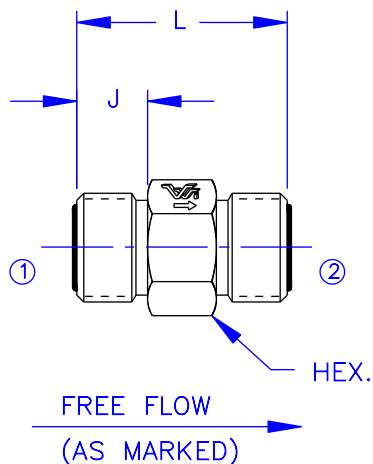

CHECK VALVE

IN-LINE / HIGH PRESSURE

1900FS SERIES
 POPPET TYPE
 MALE ORS TO MALE ORS



DESCRIPTION

- AN IN-LINE STYLE, CHECK VALVE INTENDED FOR BLOCKING FLUID FLOW.

OPERATION

- FLOW FROM "1" TO "2" IS ALLOWED WITH A STANDARD CRACK PRESSURE OF 5 PSI.
- FLOW FROM "2" TO "1" IS BLOCKED WITH A SPRING BIAS TO ASSIST IN STATIC AND LOW LOAD CONDITIONS.

FEATURES

- STEEL BODY AND POPPET.
- LOW INTERNAL LEAKAGE, 5 DPM.
- NO INTERNAL PACKINGS.
- * SPECIAL CRACK PRESSURES AVAILABLE UPON REQUEST.

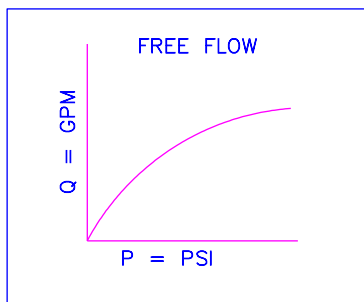

- SPECIFICATIONS -	
HYDRAULIC SYMBOL	
OPERATING PRESSURE	5000 PSI
TEMPERATURE RANGE	250°F TO -40°F
STANDARD CRACK PRESSURE	5 PSI *
ALL DIMENSIONS IN INCHES	

- ORDERING INFORMATION -	
ASSEMBLY NUMBER	19XXFS-XX
SERIES NUMBER	19XXFS-XX
THREAD SIZE	19XXFS-XX
CRACK PRESSURE (PSI) (IF NON-STANDARD)	19XXFS-XX

MODEL	INLET / OUTLET 1/2	THREAD	CAPACITY	L	J	HEX.
1906FS	#6 ORS	11/16-16	5 GPM	1.250	0.44	0.750
1908FS	#8 ORS	13/16-16	8 GPM	1.375	0.50	0.875
1910FS	#10 ORS	1-14	15 GPM	1.700	0.61	1.062
1912FS	#12 ORS	1 3/16-12	30 GPM	1.875	0.67	1.250
1916FS	#16 ORS	1 7/16-12	45 GPM	2.125	0.69	1.500



Vonberg Valve, inc.

HYDRAULIC VALVE SPECIALISTS

3800 INDUSTRIAL AVE.
 ROLLING MEADOWS, IL 60008-1085
 PH: (847) 259-3800 FAX: (847) 259-3997