

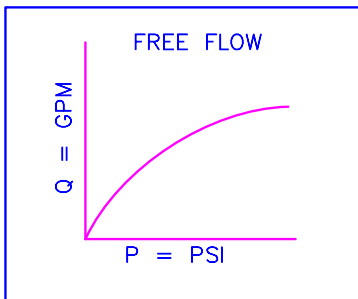

SHUTTLE VALVE

60125 SERIES

BALL TYPE
FEMALE NPTF OR SAE

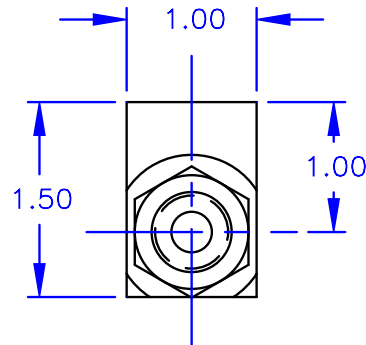
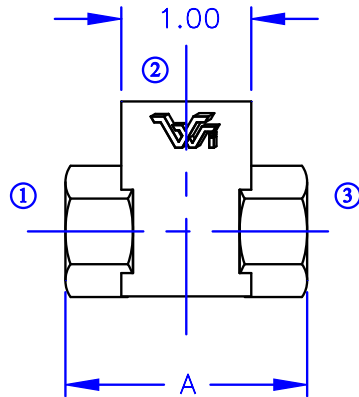

DESCRIPTION

- A SHUTTLE VALVE, FOR USE IN CIRCUITS WHERE THE PRIORITY OF FLOW DIRECTION IS GRANTED TO THE GREATER OF TWO INLETS.

OPERATION

- FLOW FROM "1" OR "3" TO "2" IS ALLOWED.
- FLOW FROM "1" TO "3" IS BLOCKED.
- FLOW FROM "3" TO "1" IS BLOCKED.

FEATURES

- ALUMINUM BODY.
- HARDENED STEEL SEATS.
- CHROME BALL.
- NO INTERNAL PACKINGS.

- SPECIFICATIONS -	
HYDRAULIC SYMBOL	
OPERATING PRESSURE	3500 PSI
TEMPERATURE RANGE	250°F TO -40°F
ALL DIMENSIONS IN INCHES	

PORT ID.	PORT SIZE	A *
2	1/4-18 NPTF	2.22
3	3/8-18 NPTF	2.22
4T	#4 SAE 7/16-20 THD	1.86
6T	#6 SAE 9/16-18 THD	1.86
8T	#8 SAE 3/4-16 THD	2.82

* "DIM. A" IS CONTROLLED BY XX DESIGNATOR

- ORDERING INFORMATION -	
ASSEMBLY NUMBER	60125-XX-ZZ**
SERIES NUMBER	_____
INLET PORTS	_____
OUTLET PORT	_____

** WHEN INLET AND OUTLET PORTS MATCH, ONLY ONE SUFFIX IS NECESSARY



Vonberg Valve, inc.

HYDRAULIC VALVE SPECIALISTS

3800 INDUSTRIAL AVE.
ROLLING MEADOWS, IL 60008-1085
PH: (847) 259-3800 FAX: (847) 259-3997