

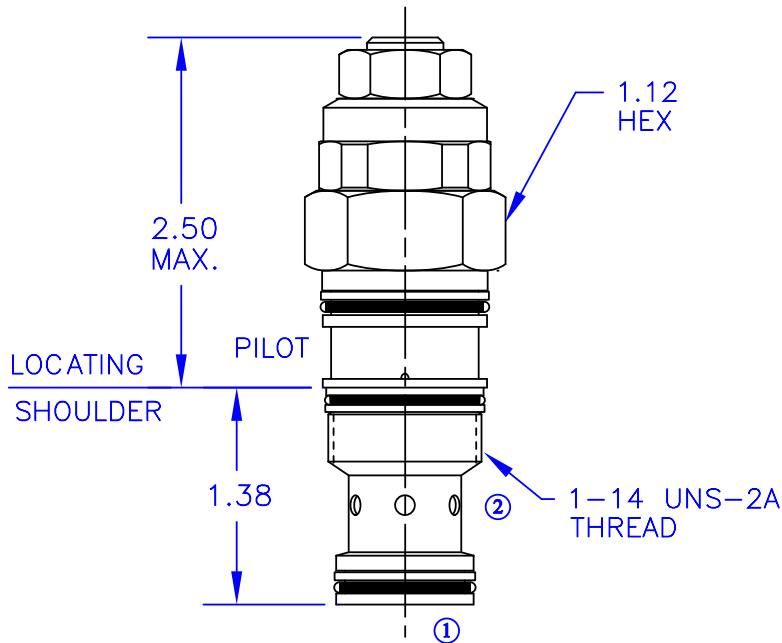

# COUNTERBALANCE

## INTERNALLY VENTED CARTRIDGE

55T2



### STYLE

- CARTRIDGE VALVE WITH AN INTERNALLY VENTED SPRING CHAMBER.

### DESCRIPTION

- THREE PORT, PILOT TO OPEN ASSIST COUNTERBALANCE VALVE WITH FREE REVERSE CHECK. INTENDED FOR MOTION CONTROL AND OVER CENTER LOAD HOLDING APPLICATIONS.

### OPERATION

- FLOW FROM "2" TO "1" IS ALLOWED WITH A STANDARD CRACK PRESSURE OF 25 PSI.
- FLOW FROM "1" TO "2" IS BLOCKED UNTIL THE RELIEF PRESSURE SETTING HAS BEEN EXCEEDED.
- FLOW FROM "1" TO "2" IS BLOCKED UNTIL A PILOT PRESSURE INVERSELY PROPORTIONAL TO THE LOAD PRESSURE IS APPLIED TO THE PILOT PORT.
- BACK PRESSURE AT PORT 2 IS ADDITIVE TO RELIEF SETTING.

### FEATURES

- ADJUSTABLE WITH LOCKING NUT
- CLOCKWISE ADJUSTMENT TO INCREASE RELIEF SETTING
- LOW LEAKAGE
- SEALED PILOT PISTON
- QUIET STABLE OPERATION
- LOW RELIEF VALVE HYSTERESIS
- PILOT RATIOS TO 10:1 AVAILABLE (\*HIGHER PILOT RATIOS MAY REDUCE FLOW CAPACITY, CONSULT FACTORY)

### - SPECIFICATIONS -

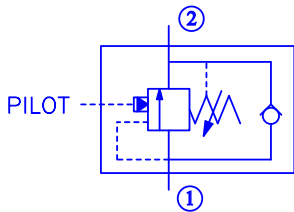
HYDRAULIC SYMBOL	
CAVITY	T-2A
FLOW CAPACITY	25 GPM*
RELIEF ADJUSTMENT	500 - 3500 PSI
CRACK PRESSURE	25 PSI
OPERATING PRESSURE	5000 PSI
TEMPERATURE RANGE	250°F TO -40°F
LEAKAGE	5 DROPS/MIN. MAX.
ALL DIMENSIONS IN INCHES	

### - ORDERING INFORMATION -

ASSEMBLY NUMBER	55T2-X-XXXX
SERIES NUMBER	_____
CAVITY	_____
PILOT RATIO	_____
RELIEF SETTING (PSI)	_____

THIS DOCUMENT, AS WELL AS ALL CATALOGS, PRICE LISTS AND INFORMATION PROVIDED BY VONBERG VALVE, INC., IS INTENDED TO PROVIDE PRODUCT INFORMATION FOR FURTHER CONSIDERATION BY USERS HAVING SUBSTANTIAL TECHNICAL EXPERTISE. DUE TO THE VARIETY OF OPERATING CONDITIONS AND APPLICATIONS FOR THESE VALVES, THE USER, THROUGH ITS OWN ANALYSIS, TESTING AND EVALUATION, IS SOLELY RESPONSIBLE FOR MAKING THE FINAL SELECTION OF THE PRODUCTS AND ENSURING THAT ALL SAFETY, WARNING AND PERFORMANCE REQUIREMENTS OF THE APPLICATION OR USE ARE MET.

THE VALVES DESCRIBED HEREIN, INCLUDING WITHOUT LIMITATION, ALL COMPONENT FEATURES, SPECIFICATIONS, DESIGNS, PRICING AND AVAILABILITY, ARE SUBJECT TO CHANGE AT ANY TIME AT THE SOLE DISCRETION OF VONBERG VALVE, INC. WITHOUT PRIOR NOTIFICATION.



**Vonberg Valve, inc.**  
HYDRAULIC VALVE SPECIALISTS

3800 INDUSTRIAL AVE.  
ROLLING MEADOWS, IL 60008-1085  
PH: (847) 259-3800 FAX: (847) 259-3997