

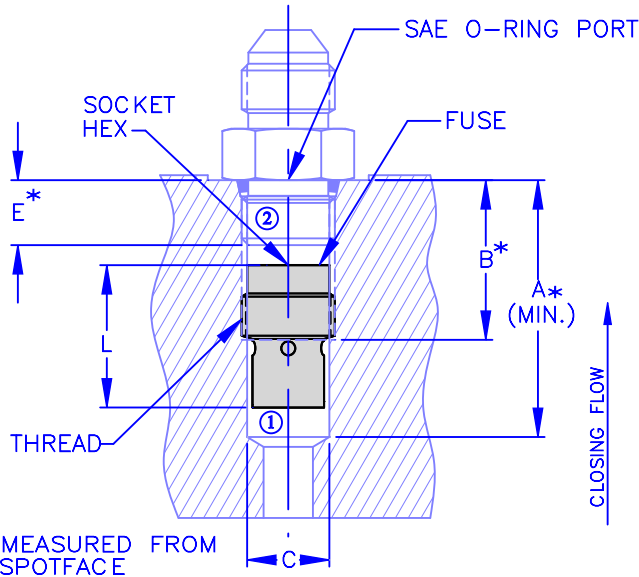

VELOCITY FUSE

IN-LINE INSERTABLE

8500 SERIES



DESCRIPTION

- AN IN-LINE VELOCITY FUSE THAT PROVIDES FULL-LINE SHUT-OFF IN THE EVENT OF A LINE FAILURE.

OPERATION

- A FLOW BELOW THE SPECIFIED CLOSING FLOW IS ALLOWED FROM "1" TO "2".
- FLOW ABOVE THE SPECIFIED CLOSING FLOW FROM "1" TO "2" IS ASSUMED TO BE A LINE FAILURE AND IS BLOCKED.
- FLOW FROM "2" TO "1" PASSES THRU THE CONTROLLING ORIFICE BUT IS UNCONTROLLED.
- CLOSING FLOW TOLERANCE=+15%-0%

FEATURES

- STEEL COMPONENTS.
- RAPID RESPONSE.
- POSITIVE CLOSE.

- SPECIFICATIONS -

HYDRAULIC SYMBOL	
OPERATING PRESSURE	3500 PSI
TEMPERATURE RANGE	250°F TO -40°F
REOPENING DIFFERENTIAL	50 PSI
ALL DIMENSIONS IN INCHES	

- ORDERING INFORMATION -

ASSEMBLY NUMBER	85XX-XX
SERIES NUMBER	85
PORT SIZE	XX
CLOSING FLOW (GPM)	

MODEL	THREAD	FLOW RANGE	L	HEX.
8504	7/16-20	0.1 - 4.0 GPM	0.66	0.125
8506	9/16-18	0.2 - 8.0 GPM	0.72	0.187
8508	3/4-16	0.5 - 15.0 GPM	1.15	0.312
8510	7/8-14	1.0 - 25.0 GPM	1.25	0.375
8512	1 1/16-12	2.0 - 40.0 GPM	1.50	0.438
8516	1 5/16-12	5.0 - 50.0 GPM	1.50	0.500
8520	1 5/8-12	5.0 - 65.0 GPM	1.85	0.625
8524	1 7/8-12	5.0 - 80.0 GPM	2.13	0.687

MODEL	A	B	C	E
8504	1.30	0.80	0.390 / 0.395	0.360
8506	1.41	0.87	0.502 / 0.515	0.391
8508	1.95	1.15	0.682 / 0.696	0.438
8510	2.15	1.05	0.798 / 0.814	0.500
8512	2.50	1.30	0.972 / 0.990	0.594
8516	2.67	1.30	1.222 / 1.240	0.594
8520	3.05	1.30	1.535 / 1.553	0.594
8524	3.38	1.37	1.785 / 1.803	0.594



Vonberg Valve, inc.
HYDRAULIC VALVE SPECIALISTS

3800 INDUSTRIAL AVE.
ROLLING MEADOWS, IL 60008-1085
PH: (847) 259-3800 FAX: (847) 259-3997